

# icountPDR

Robust Online Particle Detector



## Customer Value Proposition

The icountPDR Robust Particle Detector from Parker represents the most up to date technology in particle detection. The design dynamics, attention to detail and moulding compactness of the permanently mounted, on-line particle detector module, combined with on-board, laser based, leading-edge technology, brings to all industries a truly revolutionary, particle detector as a remarkable cost effective market solution to fluid management and contamination control.



icountPDR for mineral oil applications

## Contact Information: Product Features:

Parker Hannifin  
**Hydraulic Filter Division Europe**

**European Product  
Information Centre**  
Freephone: 00800 27 27 5374  
(from AT, BE, CH, CZ, DE, EE, ES,  
FI, FR, IE, IT, PT, SE, SK, UK)  
filtrationinfo@parker.com

www.parker.com/hfde

- Independent monitoring of system contamination trends.
- Rugged design ensures protection against environmental exposure.
- Small and compact device constructed in SS.
- Moisture %RH indicator (optional).
- Cost effective solution to prolong fluid life and reduce machine downtime.
- Continuous performance for prolonged analysis.
- Fuel, Hydraulic and phosphate Ester fluid compatible construction.
- Self diagnostic software.
- Full PC/PLC integration technology such as:- RS232 and 0-5Volt, 4-20mA, CAN(J1939) (Contact Parker for other options).
- Set up and Data logging support software included.

# icountPDR

## Robust Online Particle Detector

### Feature

Product start-up time  
Measurement Period  
Reporting interval  
Principle of operation  
International Codes  
Calibration

Recalibration  
Working pressure  
Flow Range through the icountPDR

Online Flow Range via System 20 Sensors

Ambient storage temperature  
Environment operating temperature  
Fluid operating temperature  
Computer Compatibility

Moisture sensor calibration

Operating humidity range  
Moisture sensor stability  
Power Requirement  
Current Rating  
Certification

### Analogue output options (specified when ordering)

Variable current  
Variable voltage  
CAN-bus  
Moisture sensor

### Specification

5 seconds minimum  
5 to 180 seconds  
0 to 3600 seconds via RS232 communication  
Laser diode optical detection of actual particulates  
ISO 7 – 22, NAS 0 – 12  
By recognised online methods confirmed by the relevant ISO procedures:  
**MTD** – Via a certified primary ISO 11171 automatic particle detector using ISO 11943 principles, with particle distribution reporting to ISO 4406:1996  
Contact Parker Hannifin  
2 to 420 bar (30-6000 PSI)  
**Note:** Flow may be bi-directional  
40 to 140 ml/min (Optimum Flow 60ml/min)  
(0.01 – 0.04 USGPM (optimum flow 0.016 USGPM))  
Size 0 = 6 to 25 l/min (2-7 USGPM)  
Size 1 = 24 to 100 l/min (6-26 USGPM)  
Size 2 = 170 to 380 l/min (45-100 USGPM)  
-40°C to +80°C (-40°F to +176°F)  
-30°C to +60°C (-22°F to +140°F)  
+5°C to +80°C (+41°F to +176°F)  
Parker recommends the use of a 9-way D-type connector. This can be connected to a USB port using a USB-serial adaptor. Note that these connectors/adaptors are **NOT** supplied with icountPDR units: contact Parker Hannifin for advice.  
±5% RH (over compensated temperature range of +10°C to +80°C; +50°F to +176°F)  
5% RH to 100% RH  
±0.2% RH typical at 50% RH in one year  
Regulated 9 to 40Vdc  
Typically 120mA  
IP69K rating.  
EC Declaration of Conformity

4–20mA  
0–5Vdc, 0–3Vdc (user selectable)  
to SAE J1939 (e.g. Parker IQAN)  
Linear scale within the range 5% RH to 100% RH

### Flow control

#### LOW TO MEDIUM VISCOSITY FLOW CONTROL OPTION

A pressure compensated, flow control device (Parker Hannifin part number ACC6NN023) has been developed to give the icountPDR user greater flexibility. The flow control device enables testing where flow ranges are outside the icountPDR specifications (i.e. 40–140 ml/min), or where pipe diameters do not allow the icountPDR to be installed.

The flow control device fits onto the downstream (outlet) side of the icountPDR. A 06L EO 24deg cone end hydraulic adaptor is supplied which enables connection directly to the icountPDR. Alternatively the flow control device can be fitted further downstream.

The compact design requires no setting up or further user intervention as long as the system conditions remain within the recommended pressure and viscosity ranges as below.



Working pressure range	10 to 300bar
Differential pressure range	10 to 300bar
Working viscosity range	10 to 150 Cst

## Dimensions / Installation Details

Dimensions are given in mm (inches)

Four mounting locations (two each side) to suit M8 (5/16 inch) fixings, supplied. Flange thickness is 2mm (5/64 inch)

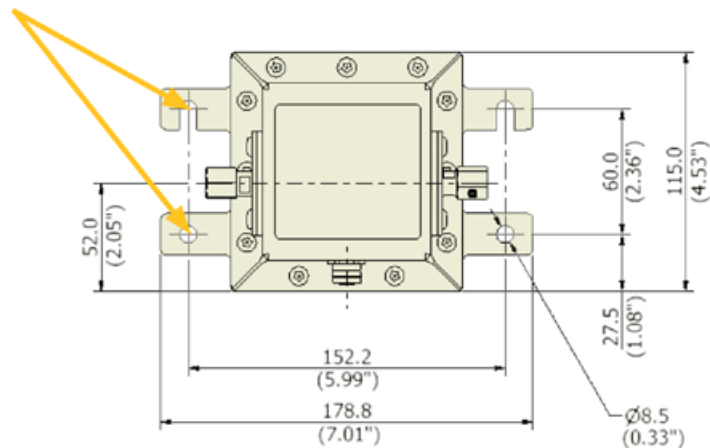
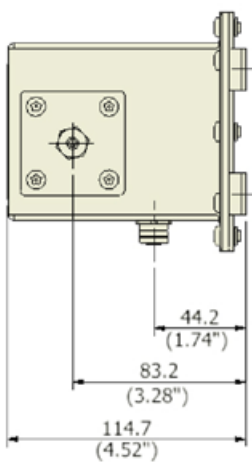
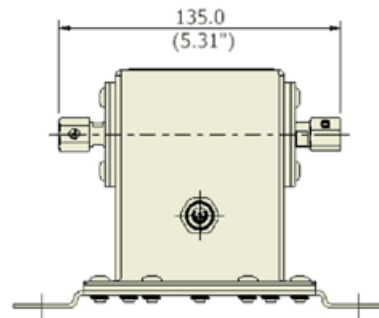

## Typical Applications

### • Mobile Equipment

- o Earth Moving Machinery
- o Harvesting
- o Forestry
- o Agriculture

Monitoring of the hydraulics, enabling the vehicles to function to their best capability under load conditions through pistons, servo valves, control rams and gear pumps.

### • Industrial Equipment

- o Production Plants
- o Fluid Transfers
- o Pulp & Paper
- o Refineries

To monitor the cleanliness of the equipment throughout the production line, from the machine tool controlled hydraulics through to contamination of fluid transfer. Ensuring the integrity of the fluid is maintained throughout the refining process.

### • Power Generation

- o Wind Turbines
- o Gearboxes
- o Lubrication Systems

With continuous monitoring the optimum level is achieved in the least amount of time.

### • Maintenance

- o Test Rigs
- o Flushing Stands

To increase efficiency of your equipment by continuously monitoring the cleanliness level of the hydraulic fluid.

### • Fuel Contamination Detection

- o Fuel Storage Tanks
- o Vehicle fuel tanks
- o Uploading fuel into an aircraft

24/7 detection of particulate levels in most fuels including aviation fuel - Jet A-1 fuel specification.

# icountPDR

## Robust Online Particle Detector

### Connections

#### Variable current output settings

See page 440 (icountPD) for tables and graphs that can be used to relate an analogue output (in mA) to an ISO and NAS code.

#### Variable voltage output settings

See page 440 (icountPD) for tables that can be used to relate the analogue output to an ISO and NAS code.

### Ordering Information

Product Configurator

Key	Fluid type	Calibration	Display	Limit Relay	Communication	Moisture sensor	Cable connector kit
IPDR	1 Mineral	2 MTD	1 None	1 No	2 RS232 / 4-20mA	1 No	40 M12, 12 pin plug connector
	3 Aviation fuel (4 channel)				3 RS232 / 0-5V	2 Yes	10 Deutsch 12-pin DT series connector
					5 RS232/CAN-bus		

Standard Products Table

Part number	Fluid type	Calibration	Display	Limit relay	Communication	Moisture	Cable connector kit
IPDR12112140	Mineral	MTD	None	No	RS232 / 4 - 20mA	No	M12, 12 pin plug connector
IPDR12112240	Mineral	MTD	None	No	RS232 / 4 - 20mA	Yes	M12, 12 pin plug connector
IPDR12113140	Mineral	MTD	None	No	RS232 / 0 - 5V	No	M12, 12 pin plug connector
IPDR12113240	Minera	MTD	None	No	RS232 / 0 - 5V	Yes	M12, 12 pin plug connector

Accessories

Part number	Description
ACC6NN013	12Volt regulated power supply EUR, UK, USA Set
ACC6NN023	Flow control valve, industrial fittings tube 06L-G1/8A-M16 connector
ACC6NN017	1m RS232 TO USB CABLE KIT
ACC6NN024	5m M12 - 12 PIN CABLE FEMALE
ACC6NN035	M12 12 PIN - 12 PIN Deutsche cable