



GLF Series

Low Pressure Tank Top Return Line Filters



ENGINEERING YOUR SUCCESS.



Preventive

- fights costly equipment maintenance
- reduces system downtime
- controls solid contaminants
- protects fluid & system components

GLF Series

The Parker GLF low pressure return line filter is engineered to deliver efficient contamination control and performance in today's demanding hydraulic circuits. The Parker GLF is designed to maximize capacity and element life while maintaining low pressure drop, even in cold start conditions. The optional two port design provides the user installation flexibility and reduces installed cost. The inside-to-outside flow path confines contaminant during element service and minimizes contaminant exposure to the reservoir. The GLF offers pressure gauge and pressure switch ports for visual or electrical switch monitoring of the installed element.



GLF Series

Typical Applications

- Deck and Mobile cranes
- Fire fighting equipment
- Forwarders
- Hydraulic presses
- Marine steering units
- Power packs
- Excavators
- Harvesters
- Waste balers
- Reachstackers
- Wheel loaders
- Drilling equipment
- Industrial Power units
- Telehandlers
- Aerial Equipment
- Waste management, dump and fork lift trucks

Features and Benefits

Feature	Advantage	Benefit
Filter design and element construction with perforated metal outer wrap	<ul style="list-style-type: none"> • Provides excellent flow diffusing, controlling aeration • No bowl required 	<ul style="list-style-type: none"> • Reduced cost and assembly weight • Optimized performance
High efficiency Microglass media maximizing filtration area	<ul style="list-style-type: none"> • Combines high particle capture efficiency with high dirt holding capacity and lower ΔP 	<ul style="list-style-type: none"> • Cleaner fluids, longer lasting with fewer service intervals • Continuous filtration in cold start conditions • Lower operating costs
Element design includes integral bypass valve with closed bottom end cap	<ul style="list-style-type: none"> • New bypass with each element change • Ensures captured contaminants are removed with each element change 	<ul style="list-style-type: none"> • Ensures reliable bypass performance • Reduced risk for contamination during service
Optional Magnetic prefiltration	<ul style="list-style-type: none"> • Removes large ferrous contaminants 	<ul style="list-style-type: none"> • Extends element life • Visual indication of component wear
Patented filter element	<ul style="list-style-type: none"> • Promotes genuine service parts 	<ul style="list-style-type: none"> • Guaranteed quality of filtration
Inside-to-Outside filtration	<ul style="list-style-type: none"> • All captured contamination retained inside the element 	<ul style="list-style-type: none"> • No recontamination of system during the change of the element
Service friendly product design	<ul style="list-style-type: none"> • Easy servicing by simple element change • End cap Bridge grip for easy element removal 	<ul style="list-style-type: none"> • Reduces service time for filter
Visual or Electrical indicators	<ul style="list-style-type: none"> • Know exactly when to service the element 	<ul style="list-style-type: none"> • Reduces downtime with scheduled service
Top access element service	<ul style="list-style-type: none"> • Oil remains in housing • Quicker element change 	<ul style="list-style-type: none"> • No spills • Reduced maintenance costs
Head with 2 Inlet Ports	<ul style="list-style-type: none"> • Can be used as a fill port • Offers installation flexibility 	<ul style="list-style-type: none"> • All added oil is filtered • Reduced connections

GLF2 Series

GLF2-1 Element Performance



Efficiency

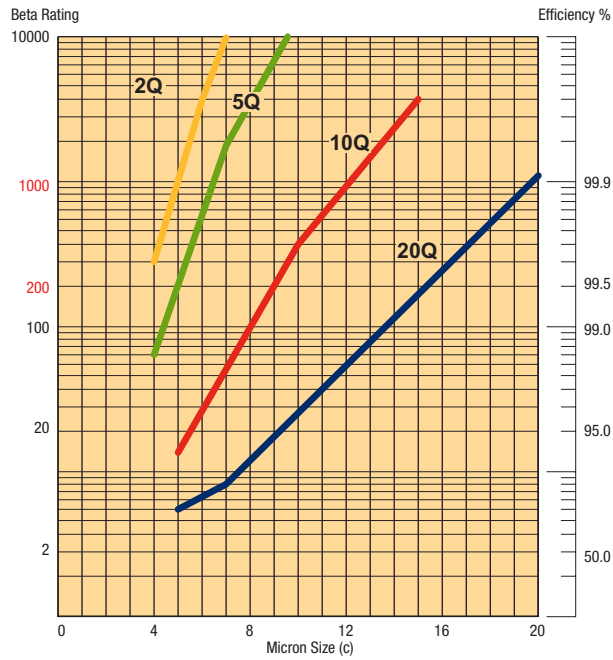

Capacity

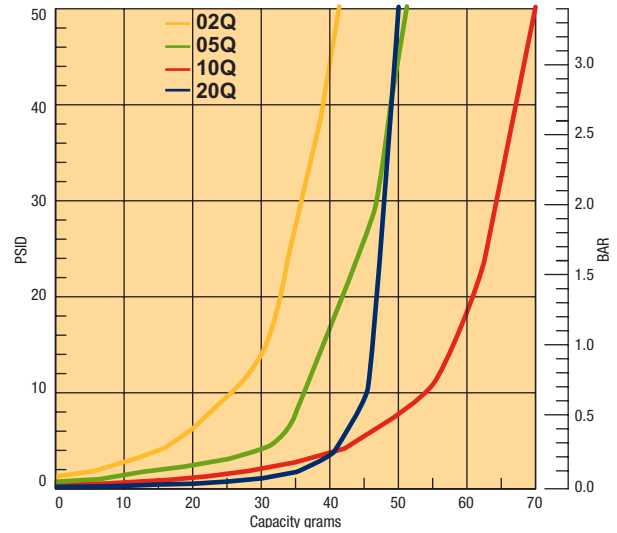

Results typical from Multi-pass tests run per test standard ISO 16889 @ 30 gpm to 50 psid terminal - 10 mg/L BUGL

Flow vs. Pressure Loss

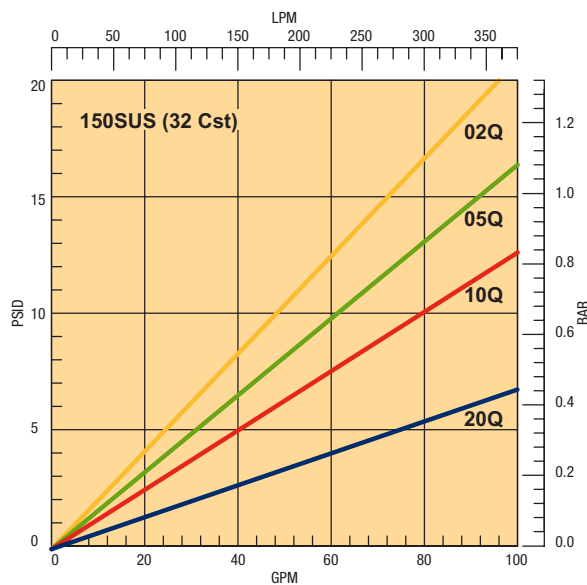

GLF2 Series

GLF2-2 Element Performance

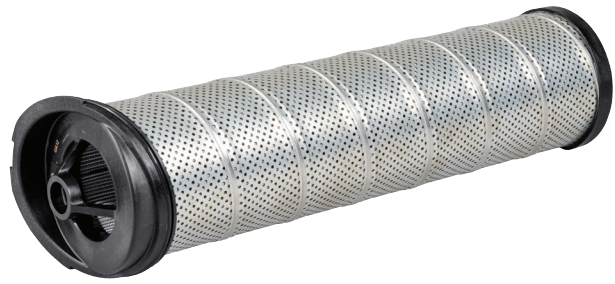

Efficiency

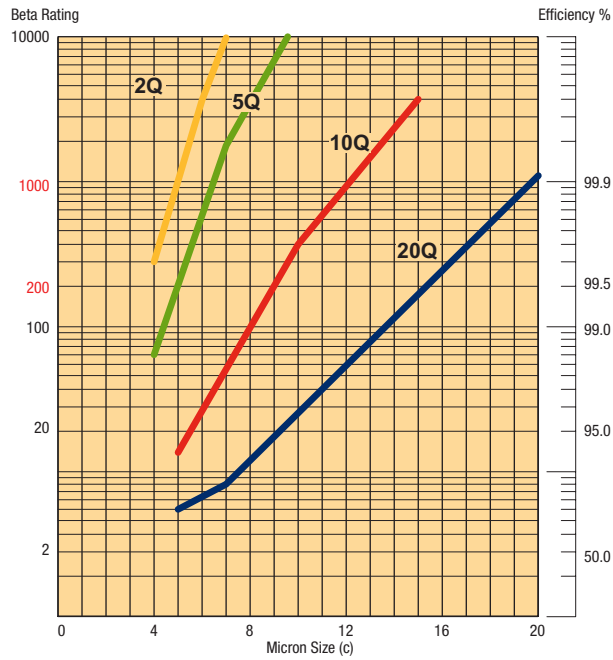

Capacity

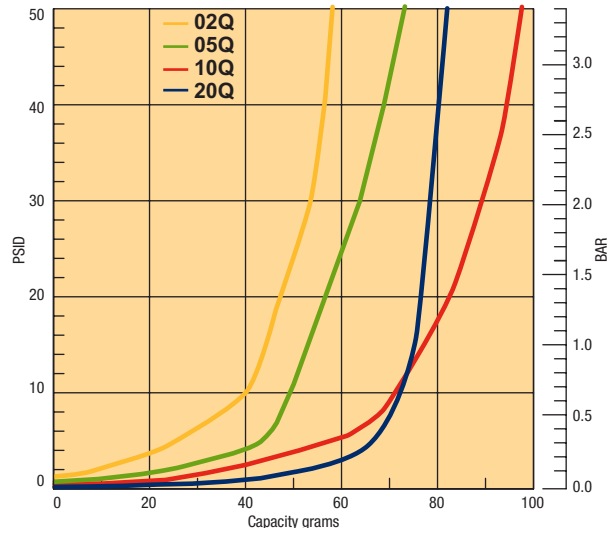

Results typical from Multi-pass tests run per test standard ISO 16889 @ 45 gpm to 50 psid terminal - 10 mg/L BUGL

Flow vs. Pressure Loss

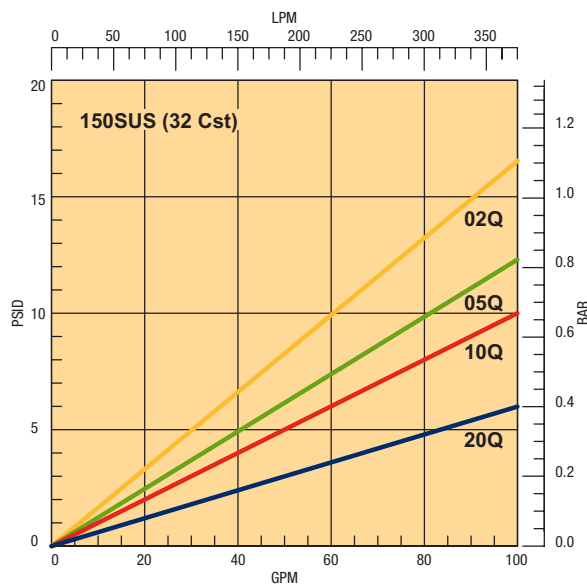

GLF3 Series

GLF3-1 Element Performance



Efficiency

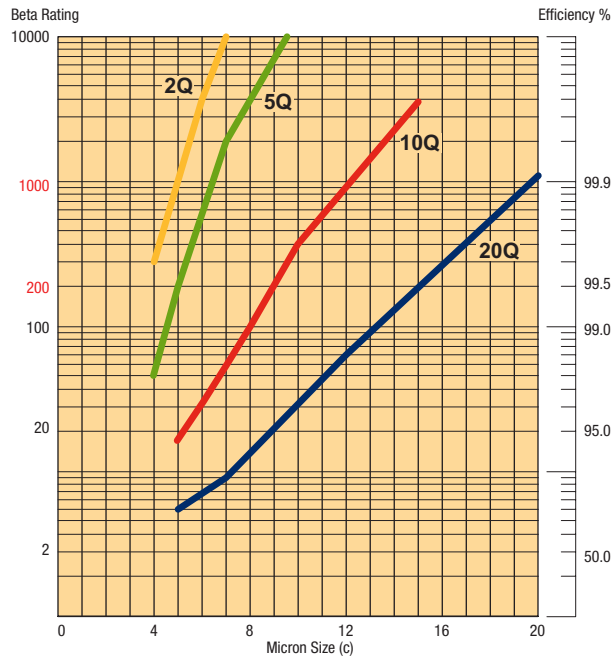

Capacity

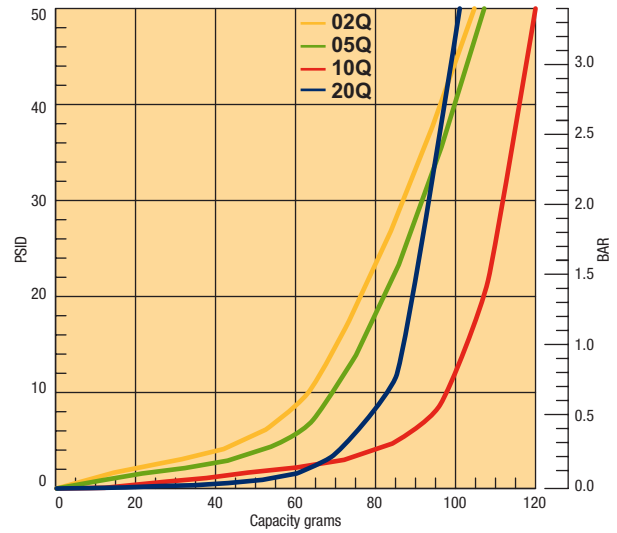

Results typical from Multi-pass tests run per test standard ISO 16889 @ 50 gpm to 50 psid terminal - 10 mg/L BUGL

Flow vs. Pressure Loss

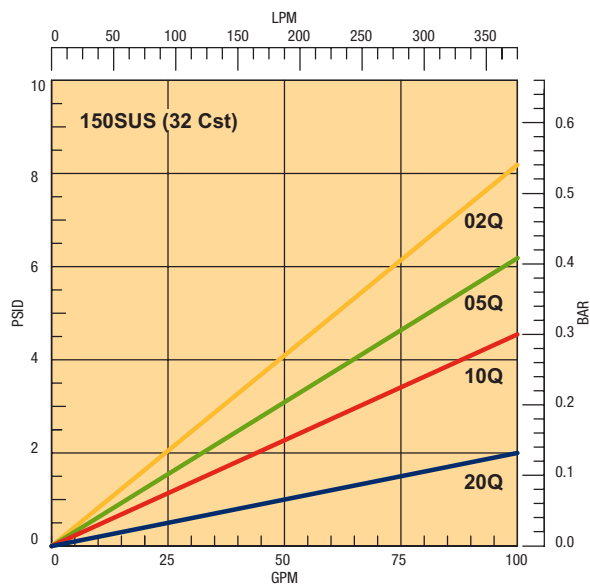

GLF3 Series

GLF3-2 Element Performance



Efficiency

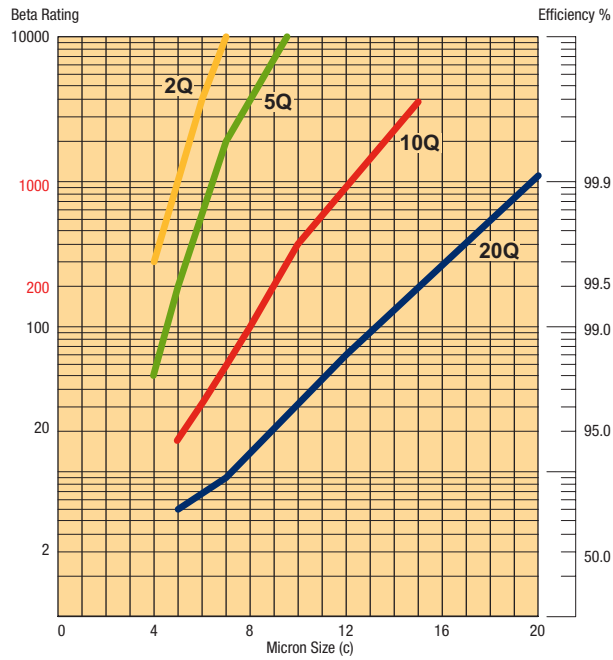

Capacity

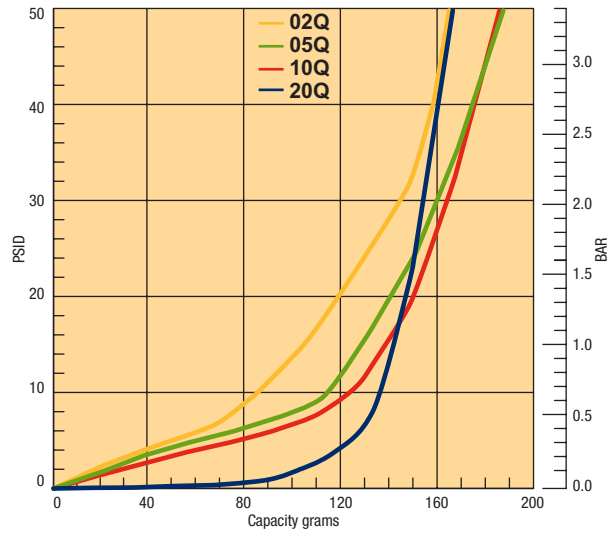

Results typical from Multi-pass tests run per test standard ISO 16889 @ 70 gpm to 50 psid terminal - 10 mg/L BUGL

Flow vs. Pressure Loss

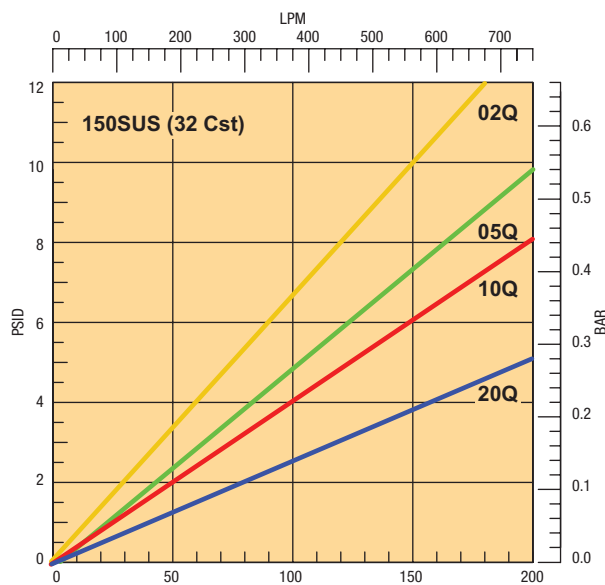

GLF4 Series

GLF4-1 Element Performance



Efficiency

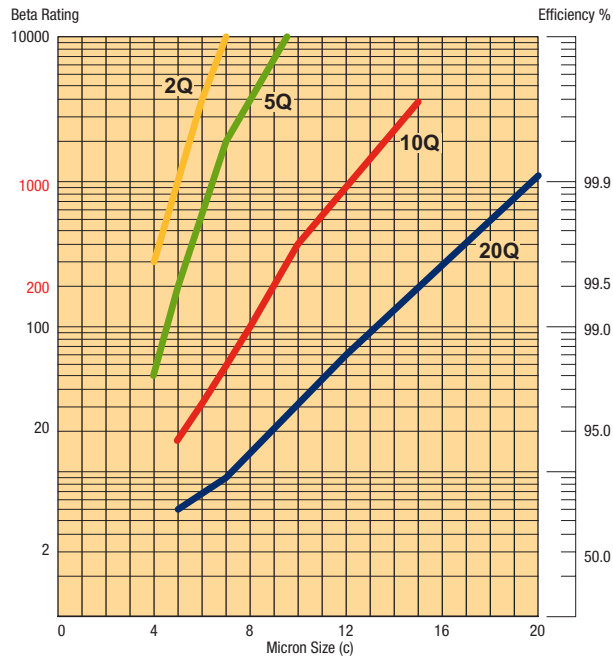

Capacity

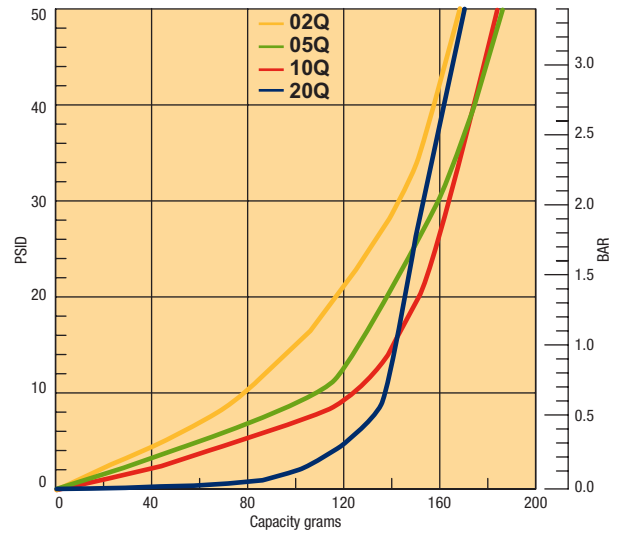

Results typical from Multi-pass tests run per test standard ISO 16889 @ 70 gpm to 50 psid terminal - 10 mg/L BUGL

Flow vs. Pressure Loss

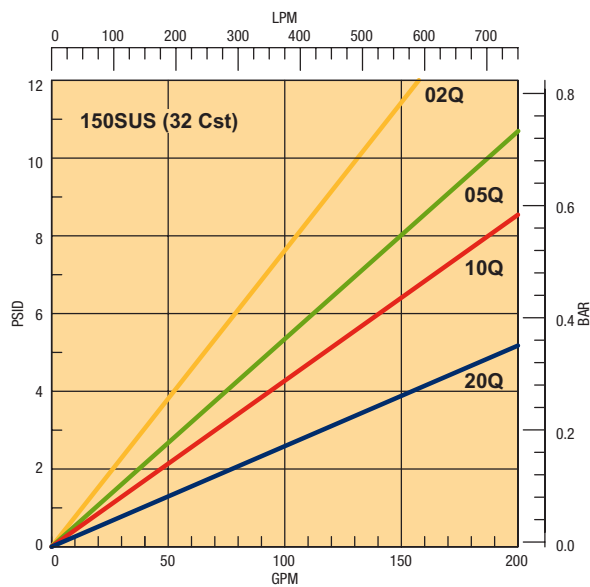

GLF4 Series

GLF4-2 Element Performance



Efficiency

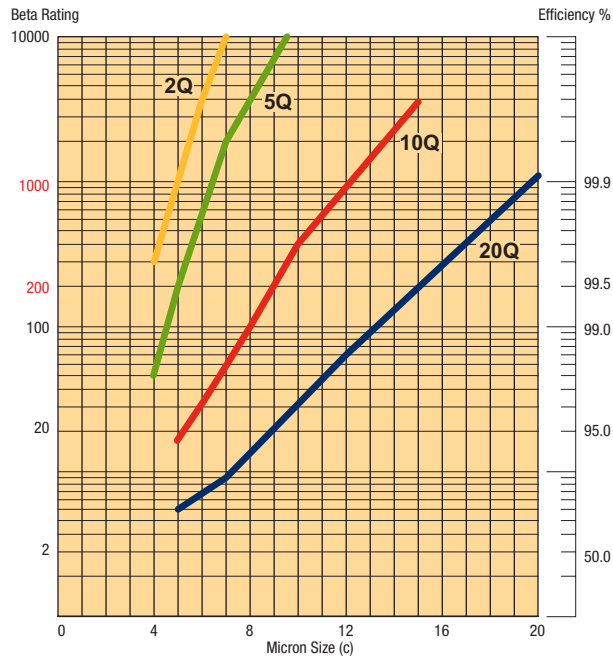

Capacity

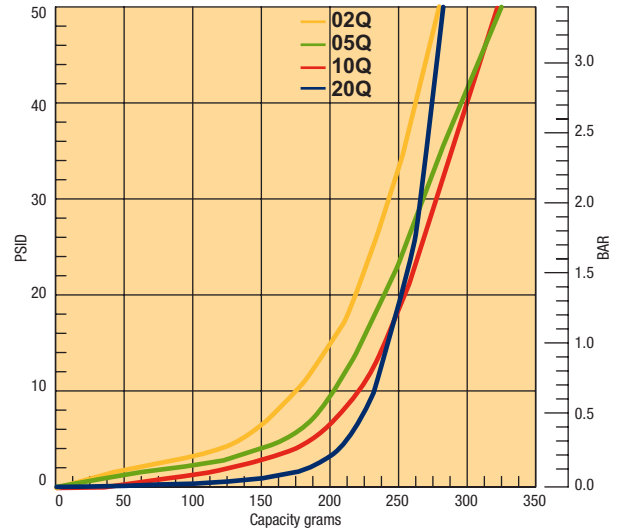

Results typical from Multi-pass tests run per test standard ISO 16889 @ 70 gpm to 50 psid terminal - 10 mg/L BUGL

Flow vs. Pressure Loss

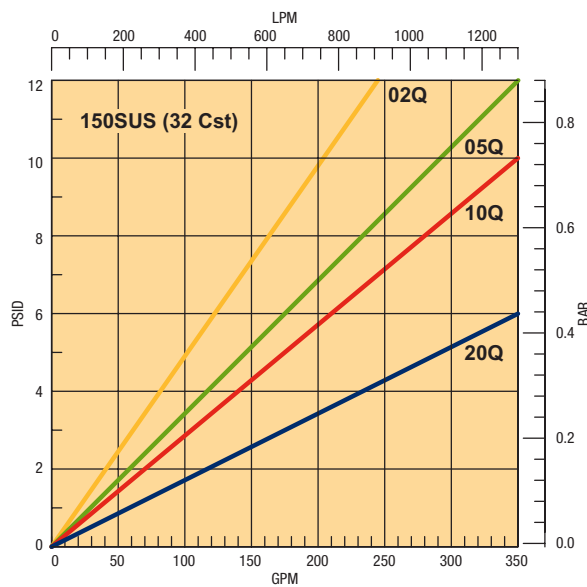

GLF2 Series

Specifications & Dimensions

Pressure Ratings:

Maximum Allowable Operating Pressure (MAOP):

150 psi (10.3 bar)

Operating Temperatures:

Nitrile: -40°F (-40°C) to 225°F (107°C)

Fluorocarbon: -15°F (-26°C) to 275°F (135°C)

Element Burst Rating:

150 psid (10.3 bar)

Filtration Media Grade:

2, 5, 10 & 20Q

Element Condition Indicators:

Gauge: 0-60 psi color coded

Switch: 30 psi SPDT 5A, 12/24

VDC and 125/250 VAC, 3-pin

Deutsch DT04-3P

Materials:

Head: Cast Aluminum Alloy

Cover: GF Nylon

Bypass Valve: GF Nylon, Music wire

Filter Media: Microglass composite

Element End Caps: GF Nylon

Weights (approximate):

GLF2-14 lbs. (1.81 kg)

GLF2-25 lbs. (2.27 kg)

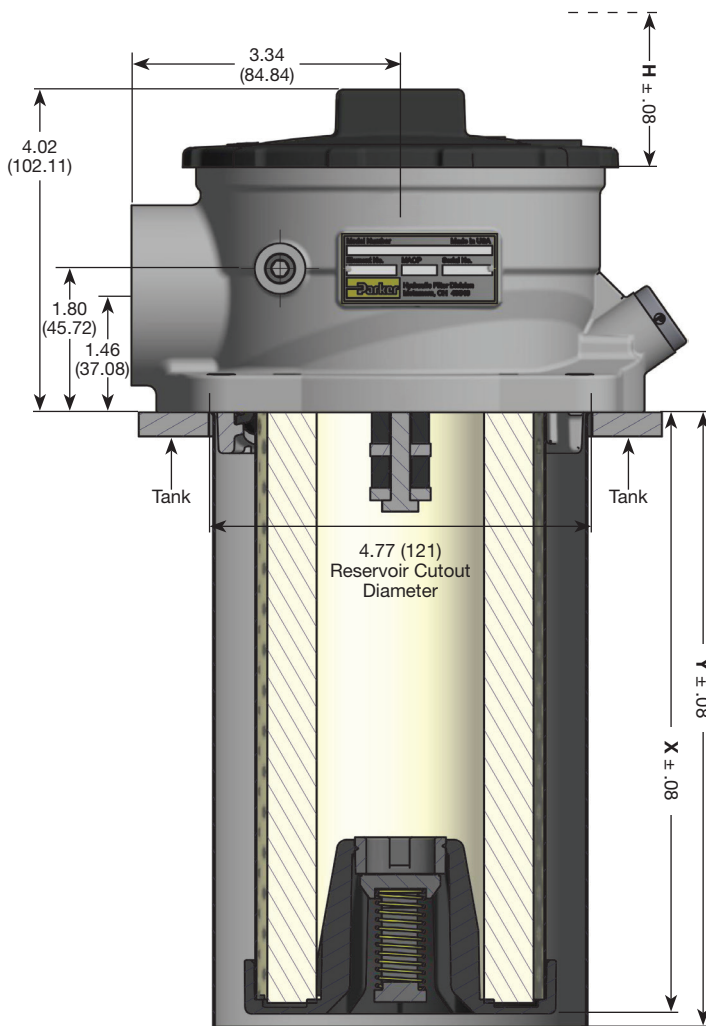

Linear Measure: inch (mm)

Drawings are for reference only.
Contact factory for current version.

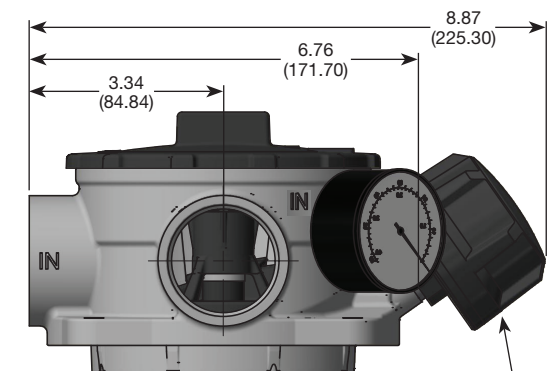
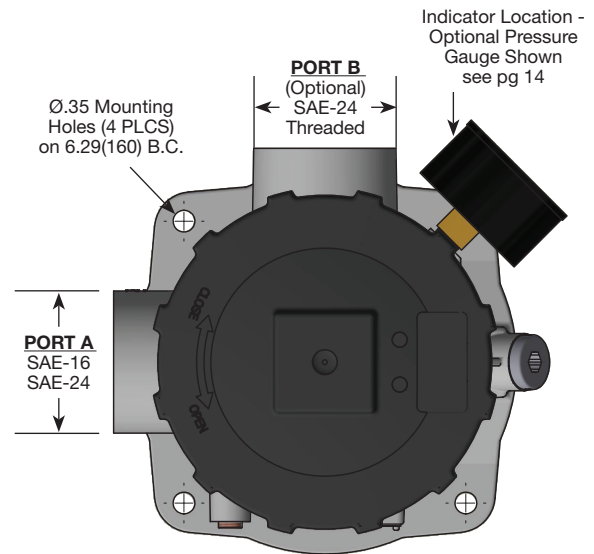

Model	X Element Depth	Y Drop Tube	H Element Removal Clearance
GLF2-1	7.49 (190.2)	7.65 (194.31)	9.04 (229.6)
GLF2-2	11.26 (286.0)	11.45 (290.8)	12.81 (325.4)

GLF3 Series

Specifications & Dimensions

Pressure Ratings:

Maximum Allowable Operating Pressure (MAOP):

150 psi (10.3 bar)

Operating Temperatures:

Nitrile: -40°F (-40°C) to 225°F (107°C)

Fluorocarbon: -15°F (-26°C) to 275°F (135°C)

Element Burst Rating:

150 psid (10.3 bar)

Filtration Media Grade:

2, 5, 10 & 20Q

Element Condition Indicators:

Gauge: 0-60 psi color coded
Switch: 30 psi SPDT 5A, 12/24 VDC and 125/250 VAC, 3-pin Deutsch DT04-3P

Materials:

Head & Cover: Cast Aluminum Alloy

Bypass Valve: GF Nylon, Music wire

Filter Media: Microglass composite

Element End Caps: GF Nylon

Weights (approximate):

GLF3-17 lbs. (3.18 kg)

GLF3-28 lbs. (3.63 kg)

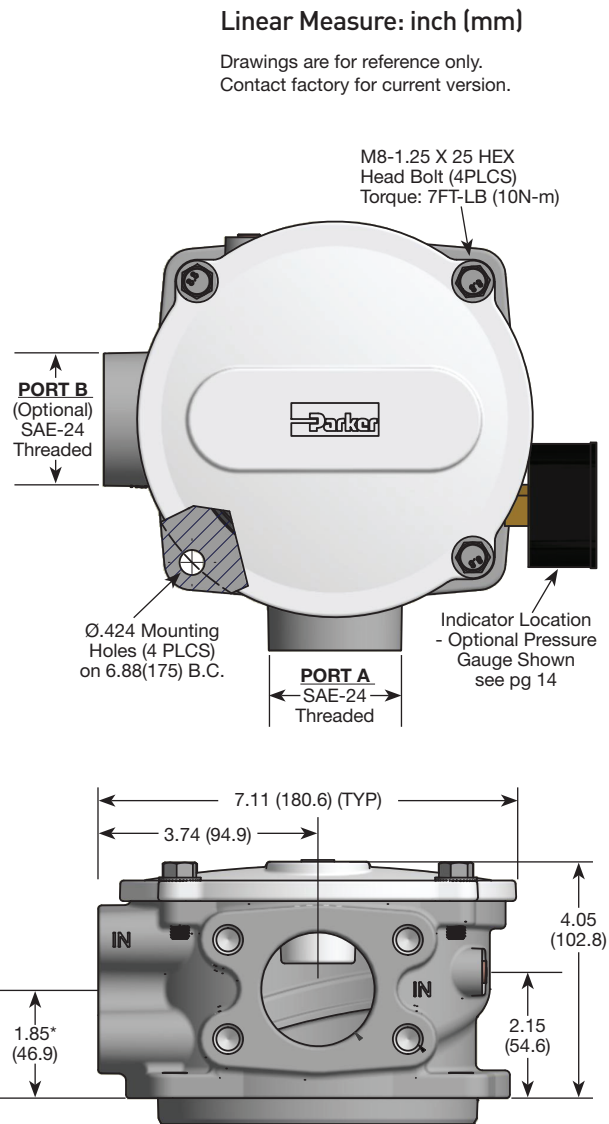
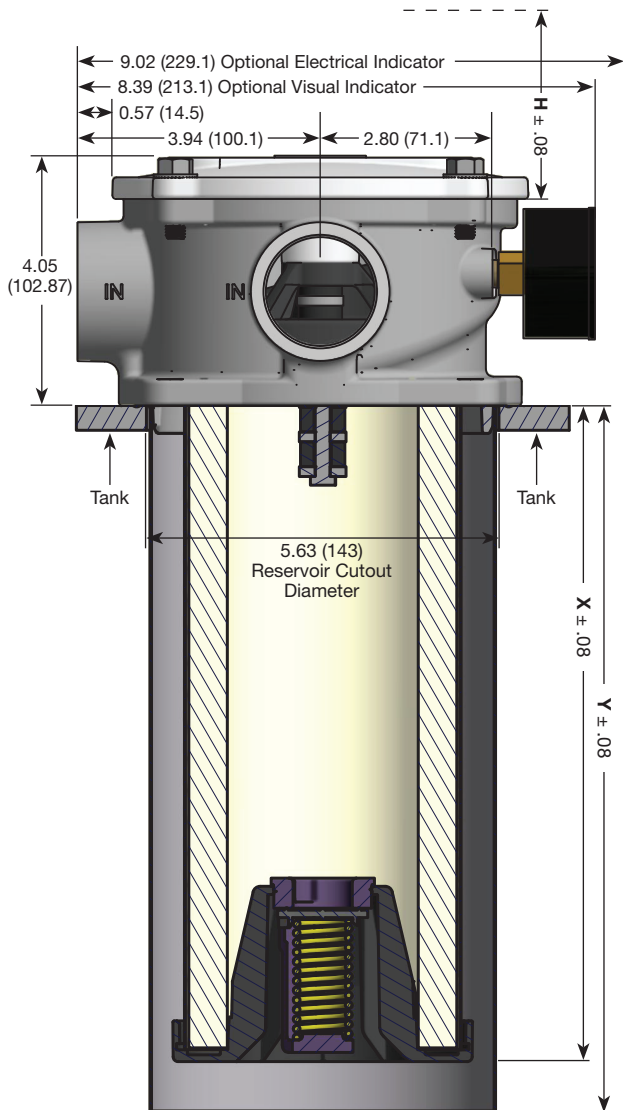

Linear Measure: inch (mm)

Drawings are for reference only. Contact factory for current version.

Model	X Element Depth	Y Drop Tube	H Element Removal Clearance
GLF3-1	10.48 (266.2)	11.65 (295.9)	12.8 (325.1)
GLF3-2	16.68 (423.7)	17.48 (443.9)	19.00 (482.6)

*Check to ensure flange clearance. Weld plate or low profile flange kit may be required.

Dual 2" SAE Code 61 Flange Face Option
See Typical Flange Dimensions pg 12

GLF4 Series

Specifications & Dimensions

Pressure Ratings:

Maximum Allowable Operating Pressure (MAOP):

150 psi (10.3 bar)

Operating Temperatures:

Nitrile: -40°F (-40°C) to 225°F (107°C)

Fluorocarbon: -15°F (-26°C) to 275°F (135°C)

Element Burst Rating:

150 psid (10.3 bar)

Filtration Media Grade:

2, 5, 10 & 20Q

Element Condition Indicators:

Gauge: 0-60 psi color coded

Switch: 30 psi SPDT 5A, 12/24

VDC and 125/250 VAC, 3-pin

Deutsch DT04-3P

Materials:

Head & Cover: Cast Aluminum Alloy

Bypass Valve: GF Nylon, Music wire

Filter Media: Microglass composite

Element End Caps: GF Nylon

Weights (approximate):

GLF4-19 lbs. (4.08 kg)

GLF4-210 lbs. (4.54 kg)

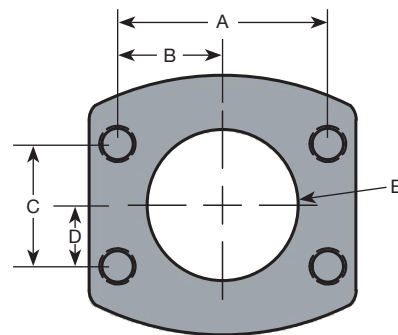
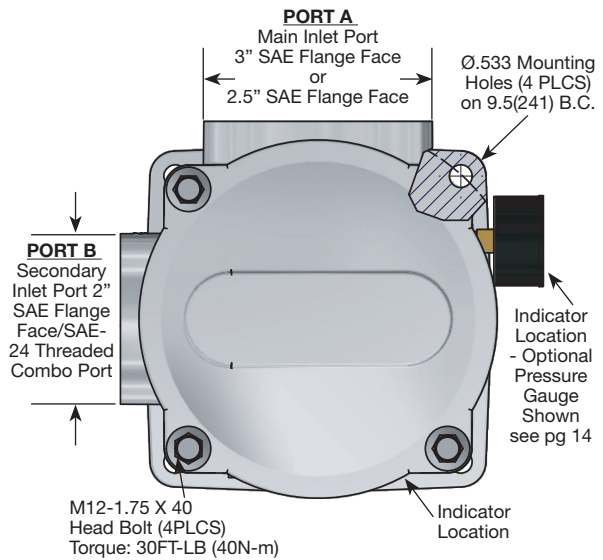
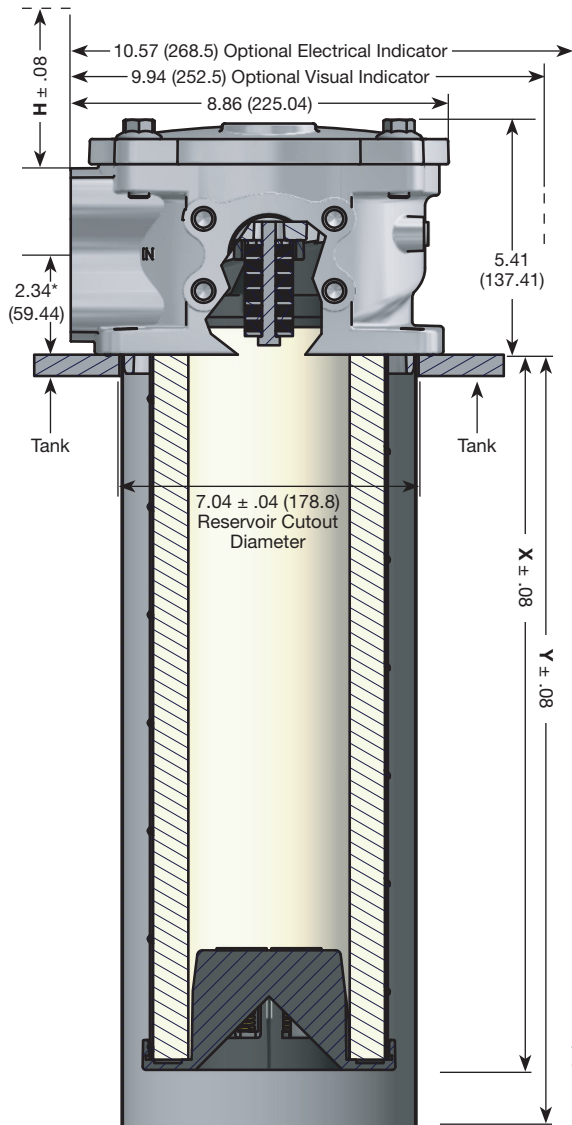

Typical Flange Dimensions Reference SAE J518

Port	A	B	C	D	E (Ø)	Thread
2"	3.06 (77.7)	1.53 (38.86)	1.69 (42.93)	.84 (21.33)	2 (50.8)	1/2-13 UNC
2.5"	3.50 (88.9)	1.75 (44.45)	2.00 (50.8)	1.0 (25.4)	2.5 (63.5)	1/2-13 UNC
3"	4.19 (106.7)	2.09 (53.09)	2.44 (61.97)	1.22 (30.99)	3 (76.2)	5/8-11

*Check to ensure flange clearance. Weld plate or low profile flange kit may be required.

Model	X Element Depth	Y Drop Tube	H Element Removal Clearance
GLF4-1	10.56 (268)	11.83 (300.5)	12.8 (325.1)
GLF4-2	16.78 (426)	18.04 (458.2)	19.00 (482.6)

GLF Series

Parts List

Item	Qty	Description	Part Number
1	1	Head GLF2, SAE-16 inlet port	946902
		Head GLF2, SAE-24 inlet port	946903
		Head GLF2, 2 x SAE-24 inlet ports	946319
		Head GLF3, SAE-24 inlet port	945848
		Head GLF3, 2 x SAE-24 inlet ports	945852
		Head GLF3, 2x2" SAE Code 61 Flange Face Inlet Ports	946317
		Head GLF4, 1x2.5", 1x2" SAE Code 61 flange face inlet ports	946270
		Head GLF4, 1x3", 1x2" SAE Code 61 flange face inlet ports	946285
2	1	GLF2 cover	84.21.471.52
		GLF3 cover	945858
		GLF4 cover	946289
3	1	Drop tube GLF2-1	85.01.016.121*
		Drop tube GLF2-2	85.01.016.122*
		Drop tube GLF3-1	85.01.016.132*
		Drop tube GLF3-2	945891*
		Drop tube GLF4-1	946564*
		Drop tube GLF4-2	946565*

Item	Qty	Description	Part Number
4	1	Name plate	920928
5	2	1/8 - 27 pipe plug	900782
not shown		GLF3 M8 - 1.25 x 25 grade 8.8 bolt serrated flange	946559
		GLF4 M12 - 1.75 x 40 grade 8.8 bolt serrated flange	946581
6	1	Replacement elements	See table on pg 16
7	1	GLF2 Magnet assembly	90.14.086.32*
		GLF3 Magnet assembly	90.14.086.33*
		GLF4 Magnet assembly	946455*
8	1	Pressure gauge	946326*
		Pressure switch	946367*
9	1	GLF2 Base Gasket nitrile	81.05.150.32
		GLF2 Base Gasket fluorocarbon	81.05.152.32*
		GLF3 Base Gasket nitrile	81.05.159.33
		GLF3 Base Gasket fluorocarbon	81.05.161.33*
		GLF4 Base Gasket nitrile	81.05.159.34
GLF4 Base Gasket fluorocarbon	81.05.161.34*		
10	1	GLF2 Cover O-ring nitrile	N72246
		GLF2 Cover O-ring fluorocarbon	V72246*
		GLF3 Cover O-ring nitrile	N72256
		GLF3 Cover O-ring fluorocarbon	V72256*
		GLF4 Cover O-ring nitrile	N72263
GLF4 Cover O-ring fluorocarbon	V72263*		
not shown		GLF2 Breather	AB.685101*
not shown		GLF2 Port Plug, Airbreather (G3/8" BSPP)	VSTI3/8EDCF
not shown		GLF2 Tank Support Ring	84.71.471.22

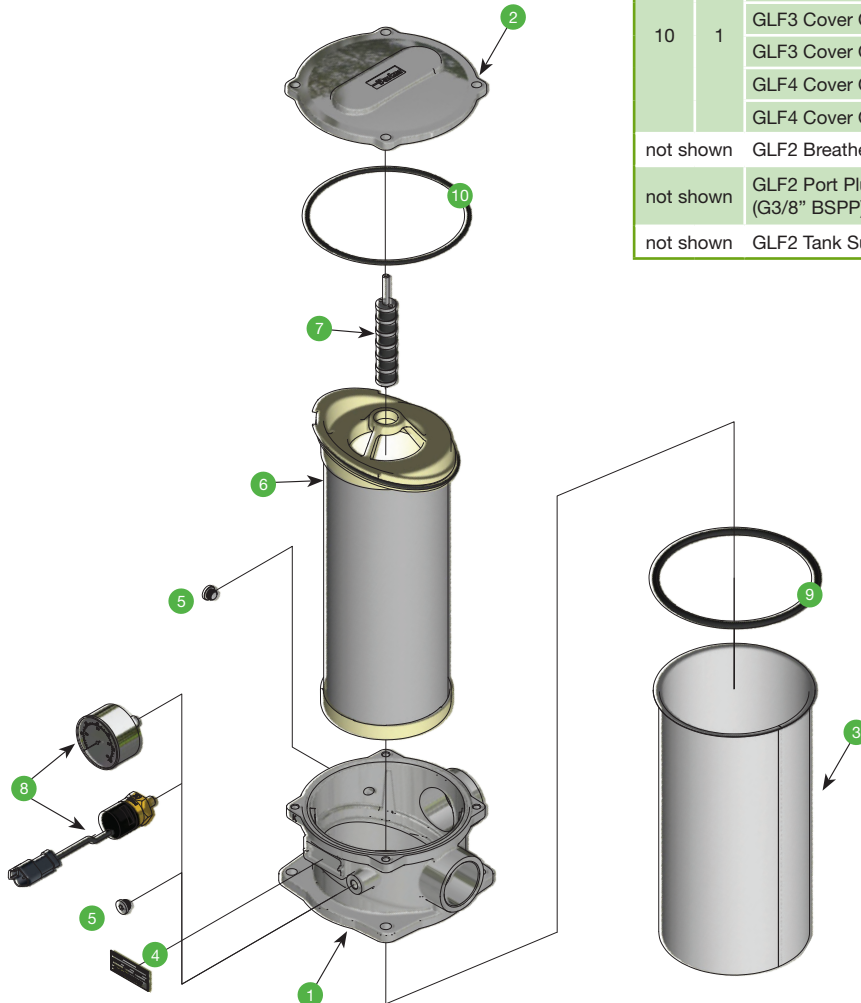

* options

GLF Series

Options and Accessories

Electrical Switch (30 psi) PN 946367

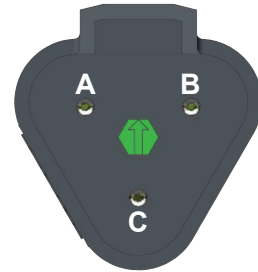
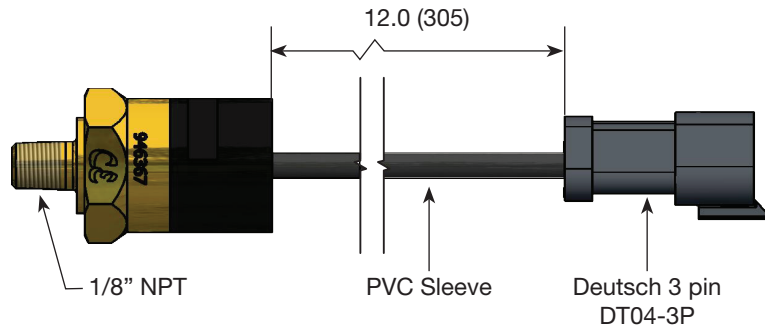

Wiring Code

Switch Contact	Receptacle
Common	Socket A
Normally Closed	Socket B
Normally Open	Socket C

Pressure Gauge PN 946326

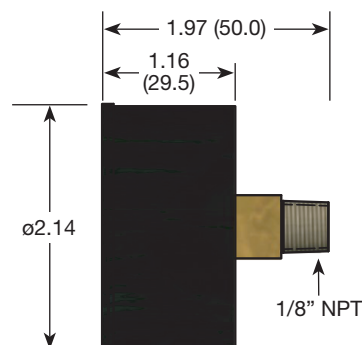
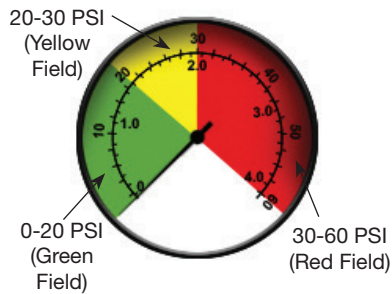

2 inch Flange Adapter Kits (flange, 4 bolts, o-ring)

Size	Part Number	
	Nitrile	Fluorocarbon
3/4 inch NPTF	924788	926013
1 inch NPTF	924787	926012
1 1/4 inch NPTF	924912	926004
1 1/2 inch NPTF	924786	926011
2 inch NPTF	924785	926010
SAE - 12	924784	926009
SAE - 16	924783	926008
SAE - 20	924913	926005
SAE - 24	924782	926007
Flange blank	924781	926006

Low Profile Split Flange Kit (nitrile)

2"	947097
3"	947098

Linear Measure: inch (mm)

Drawings are for reference only.
Contact factory for current version.

GLF Series

Options and Accessories

Weld Plates

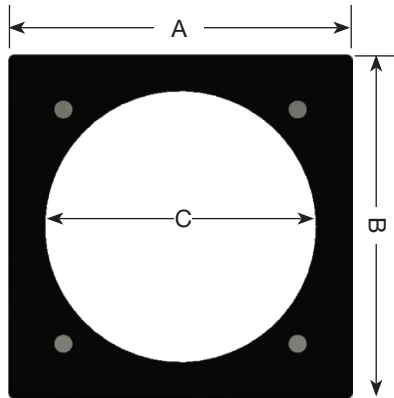

GLF3 - PN 946567

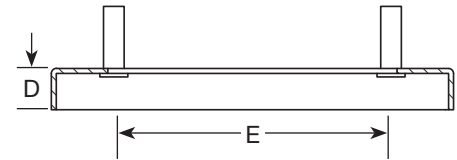

GLF4 - PN 946765

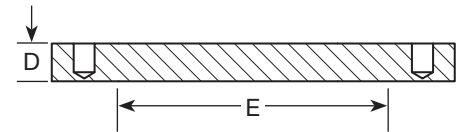

Model inch/mm	A	B	C	D	E - Hole in Reservoir	Thread
GLF3	7.15 (182)	7.15 (182)	5.63 (143)	1 (25)	5.75-6.25 (146-159)	3/8-16 UNC-2A
GLF4	8.00 (203)	8.00 (203)	7.01 (178)	.75 (19)	7.1-7.25 (180-184)	1/2-13 UNC-2B

GLF2 Breather

PN AB.685101

Construction: GF nylon and glass coupled polypropylene.

Element: Expanded Polyurethane foam, 10 micron absolute.

Seal: Nitrile.

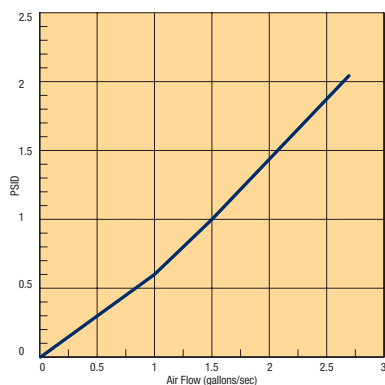
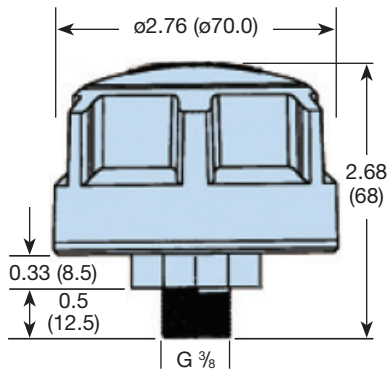

Inlet Port Options

GLF2

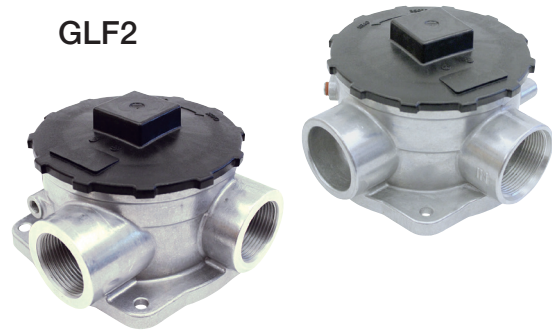

GLF3

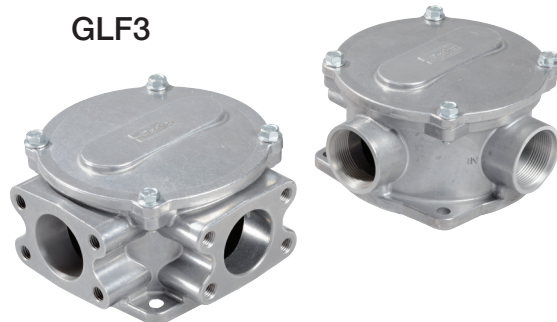

GLF4

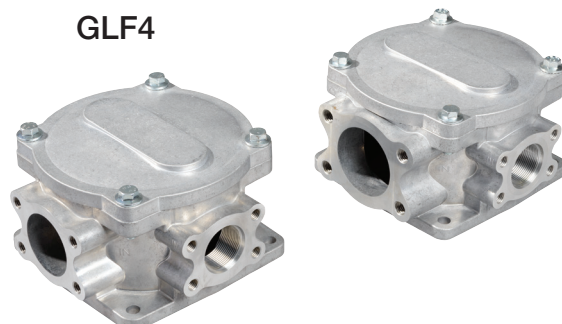

GLF Series

Operating and Maintenance Instructions

A. Start-Up

1. Check for and eliminate leaks upon system start-up.
2. Check differential pressure indicator, if installed, to monitor element condition.

B. Service

1. An element must be serviced when the indicator indicates service is required.

NOTE: If the filter is not equipped with an indicator, the element should be serviced according to machine manufacturer's instructions.

C. Servicing Dirty Element

1. Shut system down to assure that there is **NO PRESSURE OR FLOW** into the filter housing.
2. Remove the filter cover.
3. Remove and discard the contaminated element cartridge.

D. Before Installing a New Element Cartridge

1. Clean the magnetic core, if fitted, with a lint-free cloth.
2. Check all seals and replace if necessary.

E. To Install a New Element Cartridge

1. Lubricate all seals.
2. Align filter element end cap with guide posts located in head.
3. Mount new filter cartridge.
4. Re-install the cover.
5. Torque the cover bolts per drawing.

GLF Series

Low pressure filters

How To Order

Select the desired symbol (in the correct position) to construct a model code.

Example:

BOX 1	BOX 2	BOX 3	BOX 4	BOX 5	BOX 6	BOX 7	BOX 8
GLF3	2	10Q	B	P	I	S24	1

BOX 1: Basic Assembly ¹	
Symbol	Description
GLF2	Tank Top Return Line Filter
GLF3	Tank Top Return Line Filter
GLF4	Tank Top Return Line Filter

BOX 2: Length	
Symbol	Description
1	Single
2	Double

BOX 3: Media Code	
Symbol	Description
02Q	Microglass, 2 micron
05Q	Microglass, 5 micron
10Q	Microglass, 10 micron
20Q	Microglass, 20 micron

BOX 4: Seals	
Symbol	Description
B	Nitrile (NBR)
V	Fluorocarbon (FKM)

BOX 5: Indicator(s)	
Symbol	Description
P	Plugged Ports
G	Pressure Gauge, tri-color
S	Pressure Switch

BOX 6: Bypass	
Symbol	Description
I	35 psid (2.4 bar)

BOX 7: Ports	
Symbol	Description
	GLF2
S16	SAE-16 Inlet Port
S24	SAE-24 Inlet Port
2S24	Dual SAE-24 ports
	GLF3^{2,3}
S24	SAE-24 port
2S24	Dual SAE-24 ports
2Y32	Dual SAE 2" Code 61 Flange Face Inlet Ports (1/2" - 13 UNC)
	GLF4^{2,3}
2Y40	Dual SAE Code 61 Flange Face Ports (1x2 1/2" port, 1x2" port)
2Y48	Dual SAE Code 61 Flange Face Ports (1x3" port, 1x2" port)

BOX 8: Options	
Symbol	Description
1	None
M	Magnets
D	Drop Tube
MD	Magnets and Drop Tube

Notes:

- The filter includes the element you select already installed.
- A single SAE flange port connection can be achieved as follows: **GLF3**: Select "2Y32" at Box 7 and install a separately purchased flange blank kit; **GLF4**: Select "2Y40" or "2Y48" at Box 7 and install a separately purchased flange blank kit.
- Flange blank kit (2") part numbers are 924781 (nitrile), 926006 (fluorocarbon).

Replacement Elements

Media	GLF2			
	Single Length		Double Length	
	Nitrile	Fluorocarbon	Nitrile	Fluorocarbon
02Q	946849Q	946841Q	946853Q	946845Q
05Q	946850Q	946842Q	946854Q	946846Q
10Q	946851Q	946843Q	946855Q	946847Q
20Q	946852Q	946844Q	946856Q	946848Q

Media	GLF3			
	Single Length		Double Length	
	Nitrile	Fluorocarbon	Nitrile	Fluorocarbon
02Q	945894Q	945906Q	945898Q	945910Q
05Q	945895Q	945907Q	945899Q	945911Q
10Q	945896Q	945908Q	945900Q	945912Q
20Q	945897Q	945909Q	945901Q	945913Q

Media	GLF4			
	Single Length		Double Length	
	Nitrile	Fluorocarbon	Nitrile	Fluorocarbon
02Q	946431Q	946456Q	946435Q	946460Q
05Q	946432Q	946457Q	946436Q	946461Q
10Q	946433Q	946458Q	946437Q	946462Q
20Q	946434Q	946459Q	946438Q	946463Q



Hydraulic & Fuel Filtration Division

Your prescription for total system health.

Dedicated to the long term health and reliability of mission critical assets, Parker Hydraulic & Fuel Filtration Division offers you innovative products that cover your diagnostic, therapeutic and preventive needs.



Total System Health Management

Diagnostic
Monitors
Detects
Alerts

Therapeutic
Supports
Improves
Fortifies

Preventive
Long Term Defense
Long Term Value
Reduced Cost of Ownership

Your Trusted Partner in Total System Health Management

Parker Filtration Group

Aerospace Filtration Division
Greensboro, North Carolina
336 668 4444

Bioscience & Water Filtration Division
Bioscience Filtration
Oxnard, California
877 784 2234

Water Purification
Carson, California
310 608 5600

Engine Mobile Aftermarket Division
Kearney, Nebraska
308 234 1951

Engine Mobile Original Equipment Division
Modesto, California
209 521 7860

HVAC Filtration Division
Jeffersonville, Indiana
866 247 4827

Hydraulic & Fuel Filtration Division
Metamora, Ohio
419 644 4311

Industrial Gas Filtration & Generation Division
Lancaster, NY
800 343 4048

Industrial Process Filtration Division
Mineral Wells, Texas
940 325 2575

Bioscience Engineering Filtration Division EMEA
Birtley, United Kingdom
+44 (0) 191 410 5121

Engine Mobile Filtration Division EMEA
Dewsbury, United Kingdom
+44 (0) 1924 487 037

Gas Separation & Filtration Division EMEA
Team Valley, United Kingdom
+44 (0) 191 402 9000

Gas Turbine Filtration Division
Alton, United Kingdom
+44 (0) 1420 541188

Hydraulic & Industrial Filtration Division EMEA
Arnhem, Netherlands
+31 (0) 26 376 0376

Australia Filtration Division
Castle Hill, Australia
+61 2 9634 7777

China Filtration Division
Shanghai, China
+86 21 2067 2067

India Filtration Division
Chennai, India
+91 22 4391 0700

Korea Filtration Division
Hwaseon City, Korea
+82 31 359 0852

Latin America Filtration Division
Sao Paulo, Brazil
+55 12 4009 3500

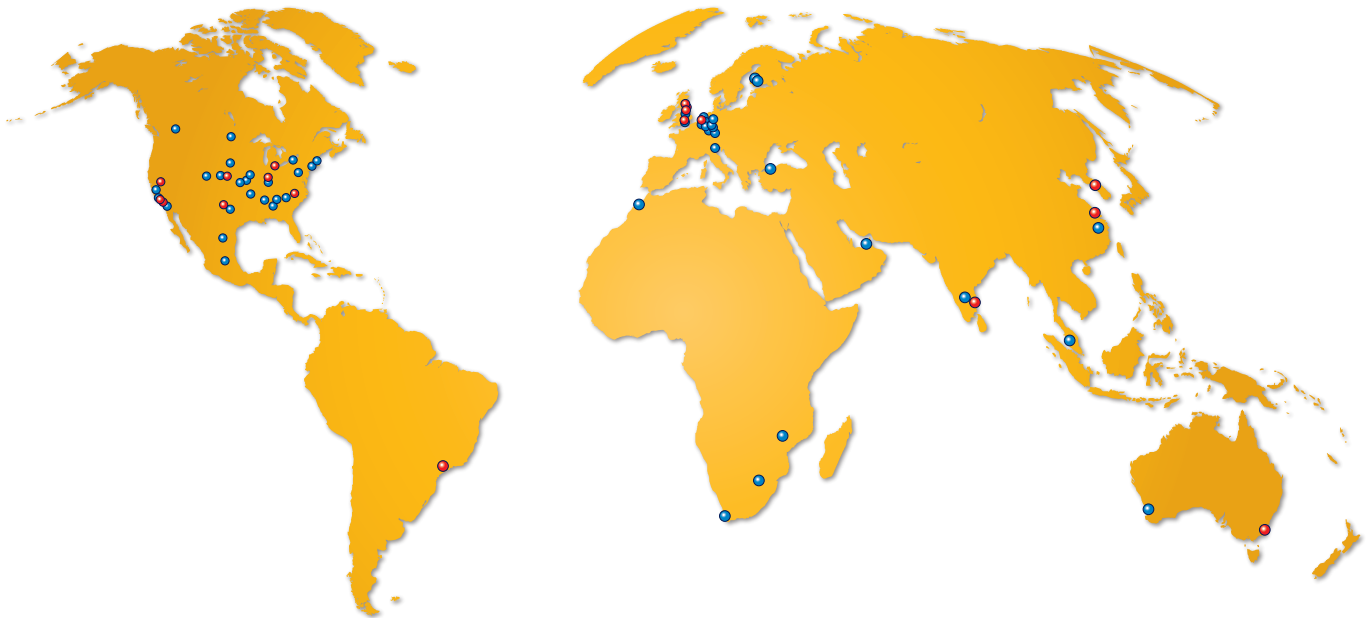

© 2018 Parker Hannifin Corporation. Product names are trademarks or registered trademarks of their respective companies.

2300-GLF_2-3-4_RevC 4/20 (PDF)



Parker Hannifin Corporation
Hydraulic & Fuel Filtration Division
16810 Fulton County Road 2
Metamora, OH 43540
phone 419 644 4311
www.parker.com/hydraulicfilter